

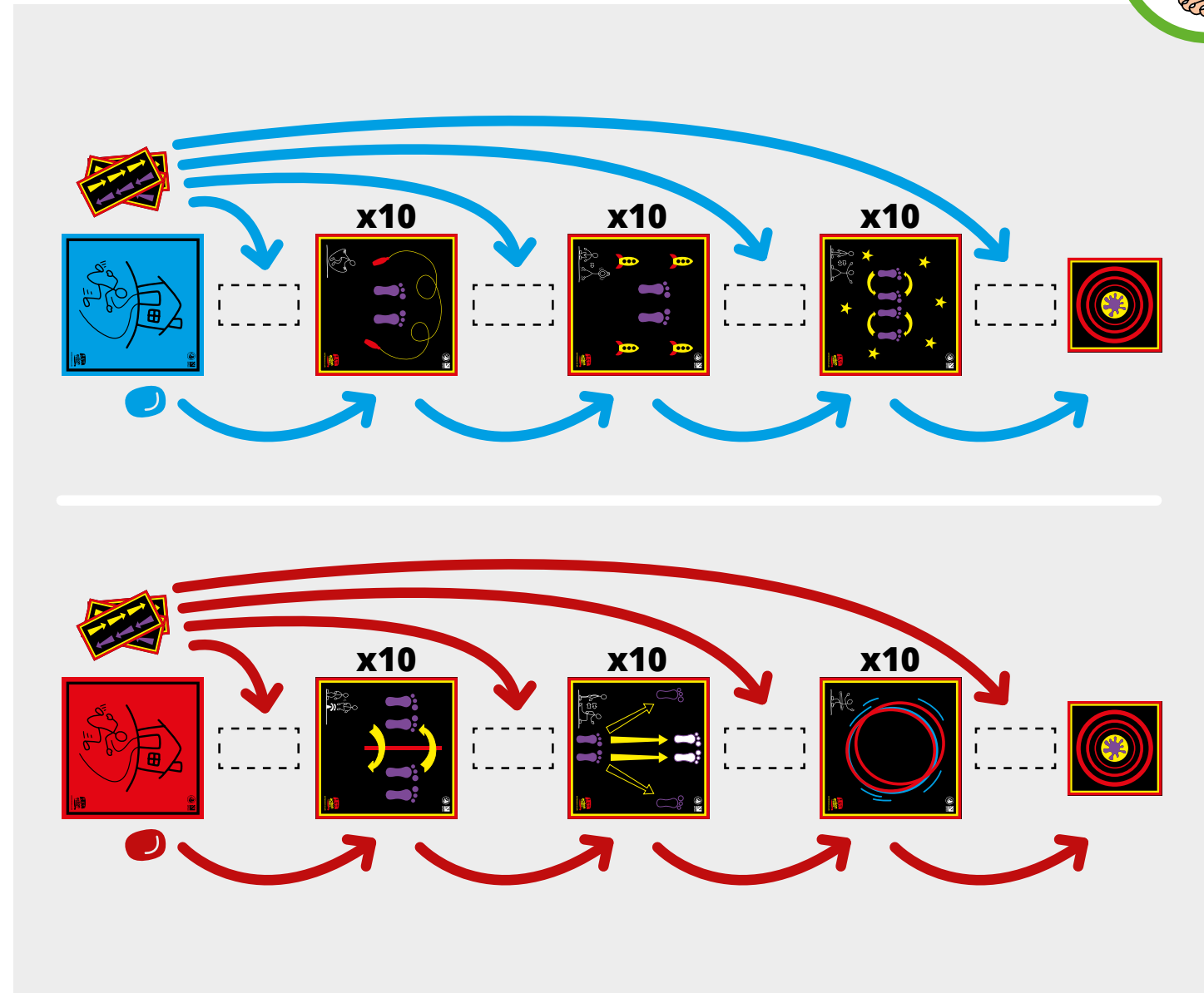

## The Setup



## Make a chain

### What's needed

- 2x Home Mats
- 10x Action Mats
- 10x Arrow Mats
- 2x Target Mats
- 2x Bean Bags
- Stopwatch/Timer
- Music

### How to play

Player 1 lays down an arrow mat between the home mat and the first Action Mat. Using the arrow mat as a stepping stone, they move onto the Action Mat and perform the exercise. Player 2 passes player 1 another arrow mat to continue the chain between the 1st and 2nd mat. Both players then move up the chain and perform the exercises.

Repeat this until the chain is complete. The last player then carries the bean bag up the chain, performing each of the exercises on the way, before finally depositing the bean bag onto the target mat at the end.



## Focus

To understand how to use teamwork strategies to develop tactics to finish first.

## Suggested age range

KS1 and KS2

## Learning outcome

To work as a team, whilst competing against others

**Reference:** Physical education programmes of study: key stages 1 and 2 National curriculum in England (DfE-00176-2013)

## Success criteria (measuring impact)

To work together with your team to get the bean bag to the end of the line as quickly as possible.

## Risks to be considered

- Suitable clothing and footwear is worn by the children and anything that could obstruct or cause injury has been removed
- The right equipment is available and has been checked
- The area is safe and clear ensuring any hazards have been removed
- Safety information is highlighted to all
- SEND pupils and other vulnerable groups (e.g. EAL) have suitable support to take part in the activities

## Assessment for learning questions (adapt for key stage)

### Pre- activity:

- Describe the difference between working cooperatively with and competing against someone?
- Describe the skills needed to cooperate and the skills needed to compete?

### Post-activity:

- Thinking about your participation today, how good were you at cooperating as team and how good were you at competing?
- What could you do better?

## Warm Up

Perform two rounds for 30 seconds each. Rest for 10 seconds in between each exercise:

- Lunges 30 second /10 second rest
- Plank 30 second /10 second rest
- Press ups 30 second /10 second rest
- Rocket jumps 30 second /10 second rest
- Sit ups 30 second /10 second rest
- Star jumps 30 second /10 second rest



## Differentiation and personalisation

- Work in pairs
- Increase the number of repetitions at each station
- Use timers to count how many repetitions can be done within a time frame
- Ask a child to lead warm-up or cool down

## Main focus

To understand how to use teamwork strategies to develop tactics to finish first.

## Cool down

Teacher led  
30secs per exercise

- Plank with a superman stretch
- Hula hoop motion without the hula hoops, slowly
- Static lunges with side stretch
- Static Rocket jumps -Squat and lift
- Calf stretch

## Reflect

In which activity do you think you have demonstrated your personal best?

What improved skills have you achieved?

Where do you feel you could have done better?

What would be your goal for next time?

What have you learnt about yourselves today?